

# OZONE SERIES

## Woltman Type Water Meter (Cold & Hot)

FM-08  
FM-09

### Salient Features:

- Extra Dry Dial.
- Superior insert with high performance & accuracy.
- Life of the meter is much higher than other bulk meters.
- Approved from FCRI.
- Hermetically sealed register ensures that all internal parts clean and prevents fogging throughout the entire lifetime of the meter.
- Robust type body to pass the strongest resistance tests in both static and dynamic conditions.
- High quality engineered materials for hydraulics and register pivot ensure high reliability and durability.
- High performance magnetic transmission ensures no part of the register is in contact with water.
- Interchangeable spare parts for easy online maintenance
- High sensitivity, low pressure loss.

### Conformity to Standards and Codes:

Design: ISO 4064

Meter Testing: ISO 4064 / OIML R-49

**Size Range:** 50mm (1-1/2") to 500mm

### Working Temperature Ratings:

- For cold < 45°C
- For hot < 130°C

### Applications:

- Industrial use.
- Agricultural applications.
- Water supply networks.



**FEDREL**

DOC.NO: VAV-1054; REV.NO:00; REV.DATE: 17-03-2017

 **TÜVRheinland®**  
Precisely Right.  
ISO 9001 : 2008

 **FCRI**

 **100%  
TEST**

 **12  
months  
WARRANTY**

[www.fedrelflowmeters.com](http://www.fedrelflowmeters.com)

## METROLOGICAL DATA

Meter Size (mm)	Class	Q4 m <sup>3</sup> /h	Q3 m <sup>3</sup> /h	Q2 m <sup>3</sup> /h	Q1 m <sup>3</sup> /h	Min. Reading	Max. Reading
50	B	30	15	3	0.45	0.01	999999
65	B	50	25	5	0.75	0.01	999999
80	B	80	40	8	1.2	0.01	999999
100	B	120	60	12	1.8	0.01	999999
125	B	200	100	20	3	0.01	999999
150	B	300	150	30	4.5	0.1	9999999
200	B	500	250	50	7.5	0.1	9999999
250	B	800	400	80	12	0.1	9999999
300	B	1200	600	120	18	1	9999999
400	B	2000	1000	200	30	1	9999999
500	B	3000	1500	300	45	1	9999999

## ACCURACY CURVE



## Head Loss Curve

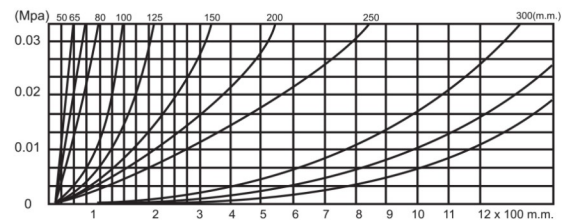

## DIMENSIONS

Size	A	B	C	D	E	F	G	H	I	J	Weight (kg)
50	200	50	165	125	17	18	3	102	4	250	12
65	200	65	185	145	17	18	3	122	4	255	13
80	225	80	200	160	17	18	3	138	8	265	15
100	250	100	220	180	19	18	3	158	8	275	19
125	250	125	250	210	19	18	3	188	8	285	22
150	300	150	285	240	21	22	3	212	8	310	28
200	350	200	340	295	23	22	3	268	12	370	42
250	400	250	405	355	26	26	3	320	12	420	80
300	450	300	460	410	28	26	4	378	12	660	115
400	600	400	580	525	34	30	4	490	16	700	187
500	800	500	715	650	42	33	4	610	20	740	256

All Dimensions are in mm unless otherwise specified.

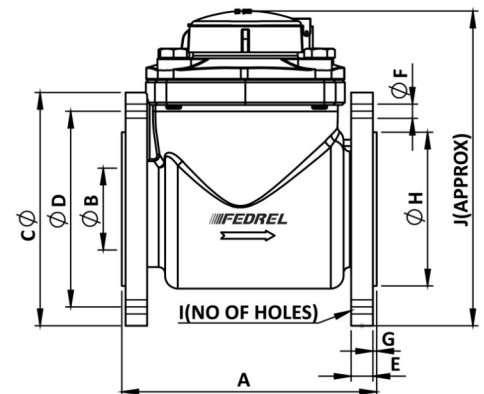

## WARRANTY

All meters are warranted against any manufacturing defect for a period of 12 months from date of supply, provided the meter has not been misused, damaged, installed for services it is not recommended or the seal has been tampered with. The company shall be liable to furnish part/ parts thereof or full water meter as the company may deem fit.

# V.A. VALVES

(FLOW METERING DIVISION)

ISO 9001-2008 Certified

Regd. Office & Works: Udyog Nagar, Gadaipur, Jalandhar City -144 004

Phone: +91-181-2601540, 2601541 Fax: +91-181-2601741

E-mail : marketing@vk-utam.com, info@fedrelflowmeters.com

Website : www.fedrelflowmeters.com

Due to continuous development program, design and data in this leaflet are subject to change without prior notice.

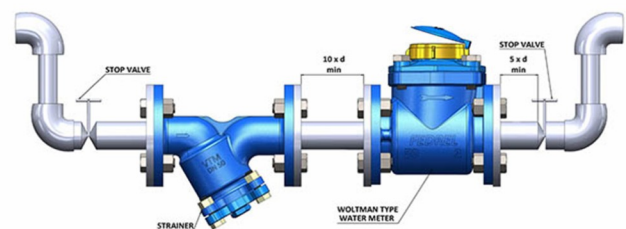

d-nominal size of water meter

U-TYPE INSTALLATION

Our associates:



PIONEERING FLUID CONTROLS

www.fedrelflowmeters.com