

## BRASS BALL VALVE

Body: Hot Forged Brass

Surface Finish: Nickel-Plated

- Working Pressure: 25BAR (1 BAR = 14.5 PSI)
- Working Temperature: -20°C to +120°C
- °C = 5/9 (°F - 32) °F = 32 + 9/5 °C
- Thread: ISO228 (BSP)

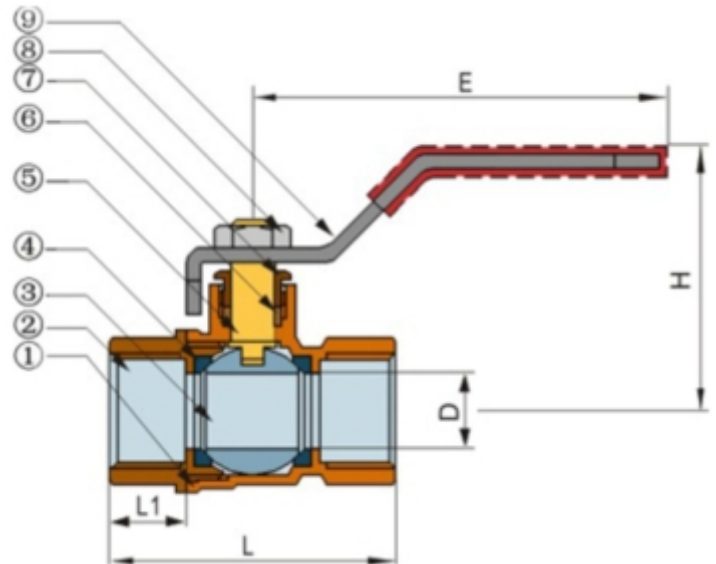

MATERIALS		
Part No.	Component	Material
1	Body	Brass
2	End Piece	Brass
3	Ball	Brass
4	Seat	PTFE
5	Stem	Brass
6	Gasket	PTFE
7	Gland Screw	Brass
8	Nut	Brass
9	Handle	Steel

DIMENSIONS						
Nominal Size		ØD	L	L1	H	E
Inch	MM					
1/4"	8	8	42	11	46	80
3/8"	10	10	46	12	46	80
1/2"	15	14	52	14	49	88
3/4"	20	19	58	14	58	95
1"	25	23	66	15	67	117
1 1/4"	32	31	75	15	71	117
1 1/2"	40	39	85.5	15.5	91	140
2"	50	49	102	18.5	98	140
2 1/2"	65	58	118.5	21.5	104	250
3"	80	70	141	23.5	115	250
4"	100	86	160	24	127	250